

DOE/ID-10289-90
cy1

DOE/ID-10289(90)
February 1991

INEEL Technical Library



116000

U.S. Department of Energy Three Mile Island Research and Development Program 1990 Annual Report

LOAN COPY
THIS REPORT MAY BE RECALLED
AFTER TWO WEEKS. PLEASE
RETURN PROMPTLY TO:
INEL TECHNICAL LIBRARY

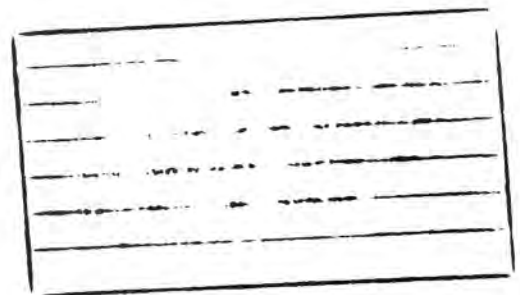

Idaho National Engineering Laboratory

U.S. Department of Energy • Idaho Operations Office



This report has been reproduced directly from the
best available copy.

Available to DOE and DOE contractors from the
Office of Scientific and Technical Information
P.O. Box 62
Oak Ridge, TN 37831
Prices available from
(615) 576-8401, FTS 626-8401

Available to the public from the
National Technical Information Service
U.S. Department of Commerce
5285 Port Royal Rd.
Springfield, VA 22161

Price: Printed Copy A03
Microfiche A01

11000

DOE/ID-10289(90)
Distribution Category: UC-523
TMI Supplement

**U.S. DEPARTMENT OF ENERGY
THREE MILE ISLAND
RESEARCH AND DEVELOPMENT PROGRAM
1990 ANNUAL REPORT**

February 1991

**Idaho National Engineering Laboratory
EG&G Idaho, Inc.
Idaho Falls, Idaho 83415**

**Prepared for the
U.S. Department of Energy
Idaho Operations Office
Under DOE Contract No. DE-AC07-76ID01570**

ABSTRACT

Defueling of the Three Mile Island Unit 2 (TMI-2) reactor was completed in 1990 as was transportation, receipt, and storage of TMI-2 core debris. The TMI-2 Technical Integration Office was closed March 1990. Completion, or significant progress toward completion, was logged in the remaining activities of the U.S. Department of Energy (DOE) programmatic effort of support to cleanup the TMI-2 facility. This report discusses that work and other TMI-2 related cleanup, research, and development activities conducted during 1990. The major topics in this report include:

- Waste immobilization
- Core debris transportation, receipt, and storage
- Accident Evaluation Program
- Technical Integration Program.

Completion of the overall DOE programmatic effort associated with the cleanup of TMI-2 will be during Fiscal Year 1991.

SUMMARY

Fuel and Waste Handling and Disposition Program

During 1990, the fuel and waste handling and disposition program continued. Fuel debris canister preparation, canister acceptance, cask loading, and rail cask shipping, receipt, and storage of core debris was conducted in accordance with the established procedures of the program.

During April of 1990, the 49th and final shipment of core debris was transported in NuPac 125-B rail casks, which hold seven fuel canisters each. A total of 342 canisters have been transported to the Idaho National Engineering Laboratory (INEL) from Three Mile Island since this activity started in July 1986. The TMI-2 core debris will be stored at the INEL for up to 30 years or until a national high-level waste repository becomes available.

Considerable progress in TMI-2 waste disposition was recorded during the year. One notable accomplishment was the disposition at the INEL of the remaining EPICOR-II prefilters that have been used for several years in a U.S. Nuclear Regulatory Commission (NRC) sponsored research program.

Significant progress in the final disposition of TMI-2 equipment and material was made. TMI-2 equipment and material used at the INEL, and cask-handling shipping equipment and materials used at TMI-2, were evaluated for disposition. Each item was identified for disposal, placed in storage, transferred to other programs, or put on public display at the Experimental Breeder Reactor I national historical landmark located at the INEL.

Accident Evaluation Program

The objectives of the DOE-sponsored TMI-2 Accident Evaluation Program are to (a) develop an understanding of what occurred inside the reactor vessel during the accident in terms of core melt progression; fission product retention and transport; and material temperatures, oxidation, and interactions; (b) develop an accident scenario based

upon this understanding; and (c) generate a computerized database of TMI-2 research data and to use the database to produce a standard problem exercise to determine possible nuclear accident scenarios.

During the course of the Accident Evaluation Program these objectives have been attained: (a) an understanding of the TMI-2 accident has evolved during the program that provides information on the consequences and dynamics of a nuclear accident; (b) this information was used to develop a detailed accident scenario; and (c) the TMI-2 database has been used to formulate potential severe nuclear accidents and to assess the effects of those accidents. These objectives are documented in reports that examine and evaluate the research performed during the Accident Evaluation Program.

To generate research important to the enhancement of nuclear safety and to increase the understanding of how a nuclear reactor vessel responds to molten fuel, NRC is sponsoring the Reactor Vessel Investigation Project. During 1990, 31 samples were obtained from the bottom head region of the TMI-2 reactor vessel for this project.

Technical Integration Program

Defueling of the reactor vessel was completed during 1990. Final defueling, cleanup, and video inspection of the TMI-2 reactor vessel was completed by the end of January. Technical assessment of the video inspection determined that an acceptable degree of reactor vessel cleanup had been attained. The goal to reduce the fuel remaining in the vessel to less than 1% of the original fuel inventory had been achieved.

The DOE Technical Integration Office at Three Mile Island, operated by EG&G Idaho, Inc., for DOE, was closed on schedule during March 1990. This marked the end of over 10-1/2 years of DOE and DOE contractor (EG&G Idaho) presence at Three Mile Island. The office coordinated activities involving several DOE national laboratories, other federal agencies, state and local agencies, private enterprise, foreign countries, and GPU Nuclear Corporation (the Three Mile Island utility).

CONTENTS

ABSTRACT	iii
SUMMARY	iv
1. INTRODUCTION	1
2. FUEL AND WASTE HANDLING AND DISPOSITION PROGRAM	2
2.1 Waste Disposition	2
2.2 Core Transportation	3
2.3 Core Receipt and Storage	3
2.3.1 Canister Totals	3
2.3.2 Core Accountability	3
2.4 Abnormal Wastes	5
2.5 TMI-2 Records Management	5
3. ACCIDENT EVALUATION PROGRAM	6
3.1 DOE Accident Evaluation Program	6
3.1.1 Final TMI-2 Accident Scenario	6
3.1.2 TMI-2 Database and Standard Problem Exercise	6
3.1.3 Sample Acquisition and Examination Program	6
3.2 NRC Reactor Vessel Investigation Project	7
4. TECHNICAL INTEGRATION PROGRAM	8
4.1 Reactor Evaluation Program	8
4.1.1 Fuel and Core Debris Removal	8
4.1.2 DOE Technical Integration Office	10
APPENDIX A—1990 TMI-2 PUBLICATIONS	A-1

FIGURES

1. Location of TMI-2 core debris—Three Mile Island versus Idaho National Engineering Laboratory	5
2. Cutaway view of the TMI-2 reactor vessel	9

TABLES

1. Summary of core debris shipping campaign	4
---	---

U.S. DEPARTMENT OF ENERGY THREE MILE ISLAND RESEARCH AND DEVELOPMENT PROGRAM 1990 ANNUAL REPORT

1. INTRODUCTION

Defueling of the TMI-2 reactor was completed during 1990. Research activities associated with cleanup and defueling continued throughout the year. Program accomplishments during 1990 include:

- Completion of final defueling and cleanup inside the reactor vessel.
- Video inspection of the reactor vessel after final defueling and cleanup. Technical assessment of the video inspection determined that an acceptable degree of reactor vessel cleanup had been attained. The TMI-2 plant will be ready for monitored storage during 1991.
- Transporting three rail cask shipments of core debris from Three Mile Island to the INEL, bringing the total to 49 rail cask shipments that have been received and processed at the INEL for storage. This represents 99+% of the original postaccident debris material.
- Disposal of the last four EPICOR-II prefilters that were used in an NRC research program at the INEL and at other DOE laboratories. The filters were disposed of in concrete high integrity containers (HICs) at the Radioactive Waste Management Complex (RWMC) located at the INEL.
- Final disposition of TMI-2 equipment and material. This involved inventorying all TMI-2 equipment and material used at the INEL, and cask-handling shipping equipment and materials used at TMI-2. Each item on the inventory list was evaluated and a deliberation was made to dispose, place in storage, transfer to other programs, or to put it on public display at the Experimental Breeder Reactor I national historical landmark located at the INEL.
- Completion of a final TMI-2 accident scenario report that will be published during 1991; completion of the Organization for Economic Cooperation and Development summary report, scheduled for publication during 1991, that explains differences and identifies the limitations of various computer code calculations used during a standard problem exercise on TMI-2; publication of a principal report of the TMI-2 Core Examination Program that documents the results of chemical and metallurgical analyses of samples obtained from the lower part of the TMI-2 reactor core; completion of a draft report that summarizes the core examination results of an international group of investigators participating in the TMI-2 Core Examination Program.
- Completion of sample gathering for the NRC-sponsored Reactor Vessel Investigation Project. This involved obtaining 31 samples from the bottom head region of the reactor vessel that will be used for research on nuclear safety and for increasing the understanding of how a reactor vessel responds to molten material.
- Progress toward closure of the overall DOE programmatic effort with completion expected during Fiscal Year 1991. This progress included closing the Technical Integration Office at Three Mile Island and transferring the remaining programmatic responsibilities to the INEL. The remaining work includes final waste disposition activities, records management closeout, completion of program reporting and documentation, and minor program closeout activities. As part of these closeout activities, this 1990 annual report will be the final annual report of the Three Mile Island program.

2. FUEL AND WASTE HANDLING AND DISPOSITION PROGRAM

2.1 Waste Disposition

Steps taken during 1990 in the disposition of TMI-2 materials temporarily stored at the INEL include the following:

- Completion of the disposition of the last four EPICOR-II prefilters, which were developed as a water treatment system used in decontaminating the approximately 2,120,000 L of contaminated water generated by the TMI-2 accident.^a The filters were disposed of in concrete HICs at the RWMC located at the INEL. The HICs were developed for the disposal of EPICOR-II prefilters used at TMI-2 and for the 46 prefilters that were previously disposed of at the U.S. Ecology commercial disposal facility located in the state of Washington. The last four filters were used in an NRC research program at the INEL and at other DOE laboratories. This disposition marked the end of the NRC program of sampling the contents of the filters. The last samples of the program were taken during 1989.

Planning for disposition included the preparation of detailed operating procedures for (a) sealing the four EPICOR-II prefilters, identified as PF-8, PF-9, PF-20, and PF-27, in HICs, (b) loading each of the HICs into a transport cask, and (c) transporting the HICs to the RWMC for burial.

The last HIC was disposed of at RWMC during April 1990. This concluded Three Mile Island programmatic activities in the disposition of HICs.

- Disposition of TMI-2 equipment and material. This activity involved the preparation of an inventory of all TMI-2 equipment and materials used at INEL facilities i.e., Test Area North (TAN), Central Facilities Area (CFA), Test Reactor Area; and cask-handling shipping equipment

a. A detailed description of the EPICOR-II water treatment system and HICs can be found in GEND Report No. 064, U.S. Department of Energy Three Mile Island Research and Development Program 1988 Annual Report, dated April 1989.

and materials used at Three Mile Island. Each item of the inventory was evaluated and a decision was made to either dispose, place in storage, transfer ownership to other programs and organizations, or to put the item on public display:

- *Disposal.* Items that were of no future value to the TMI-2 program or other programs and organizations were either disposed of as low-level waste at RWMC or sent to the Waste Experimental Reduction Facility (WERF) at the INEL for size reduction and then disposed of at RWMC.

Those items disposed of at RWMC included: (a) cask-handling equipment that was contaminated during operations inside the TAN-607 Hot Shop: cask lift fixture and stand, cask decontamination tool, lid lift fixture, and shield plugs; (b) contaminated equipment used in the EPICOR-II research and disposition program: EPICOR-II prefilter lift fixture, vent tool, and dewatering equipment. The equipment sent to WERF for size reduction included a mockup canister and EPICOR-II prefilter. One item, a portion of the cask lift fixture, could not be disposed of at RWMC since it contained lead which made it hazardous material. Arrangements have been made to dispose of it commercially at U.S. Pollution Control, Inc., Salt Lake City, Utah. Several other pieces of equipment have also been identified and will be disposed of during Fiscal Year 1991.

- *Storage.* Equipment that could be used at a later date was placed in storage. The equipment included:
 - Two NuPac 125-B shipping casks and railcars that were placed on a railroad spur at CFA. All cask handling and operational equipment from TAN, CFA, and Three Mile Island was inventoried, packaged, if needed, and stored on the railcars with the rail casks.

- Equipment used originally to handle fuel canisters at TAN during the removal of core material required for research. Reloading of core material used for research will be accomplished with this equipment. The core material includes damaged fuel samples, control rod spiders, and end fittings from the TMI-2 reactor core. After these components have been stored, arrangements will be made to dispose of the canister laydown fixture and horizontal lift fixture equipment.
- *Transfer of Ownership.* Items that could be used by other programs, organizations, and operations were transferred to their control. Some of these items included: (a) all canister-handling equipment, transferred to TAN Hot Shop Operations, for handling canisters over the estimated 30-year storage period of the TMI-2 core debris; and (b) equipment, transferred to the INEL Prototypical Consolidation Demonstration Program, needed for handling HICs.
- *Public Display.* A display is being prepared showing DOE participation in the research, development, and cleanup of TMI-2. The display will be a permanent exhibit at the Experimental Breeder Reactor I national historical landmark located at the INEL. Items to be included at the exhibit are: (a) a quarter-scale model of the NuPac 125-B shipping cask used in a drop test program, (b) a tenth-scale model of the NuPac 125-B cask, (c) a first-of-a-kind, full-sized HIC used to dispose EPICOR-II prefilters, (d) models of the damaged TMI-2 core, (e) several poster displays used at national and international conferences, (f) photographs of all phases of DOE involvement, and (g) video taped programs. The display is expected to be completed during 1991.

2.2 Core Transportation

The process of transporting TMI-2 core debris to the INEL was completed in April 1990. Fuel canister preparation and cask loading cycles were conducted in accordance with the program started in

1986.^a A total of 49 shipments were received at the INEL from 1986 through completion of the transport campaign in April 1990. Five shipments arrived at the INEL in 1986, 17 in 1987, 12 in 1988, 12 in 1989, and 3 in 1990. Table 1 shows all transports of debris through completion of the transport campaign.

2.3 Core Receipt and Storage

Figure 1 shows the percentage of TMI-2 core debris that has been transferred from Three Mile Island for storage at the INEL. The figure shows that approximately 99+% of the core debris was transferred to the INEL by the end of the transport campaign in April 1990. This amount accounts for approximately all the original TMI-2 core debris, which was estimated to be 134,356 kg.

The core debris was transported in casks by railcar to the INEL. The casks were delivered to the TAN facility by tractor/trailer where the TMI-2 debris canisters inside the casks were removed and stored in a water pit at the TAN Hot Shop.^a

Storage of TMI-2 core debris at the INEL is planned for up to 30 years or until a national high-level waste depository becomes available.

2.3.1 Canister Totals. The total number of canisters used by the completion of the defueling campaign to transport fuel debris from Three Mile Island to the INEL was 342. Of these, 268 were fuel canisters, 62 were filter canisters, and 12 were knockout canisters.

2.3.2 Core Accountability. A draft of the TMI-2 core accountability database report, entitled *Uranium and Plutonium Content of TMI-2 Defueling Canisters*, was completed. The calculated, reportable quantity of fissile material in each of the TMI-2 canisters stored at the INEL is identified in the report. The calculations were made using detailed canister loading information prepared by GPU Nuclear and from examinations of TMI-2 core debris stored at the INEL. The report will provide the basis by

a. Detailed procedures for loading, transport, receipt, and storage of rail casks from Three Mile Island to the INEL are discussed GEND Report No. 064, U.S. Department of Energy Three Mile Island Research and Development Program 1988 Annual Report, dated April 1989.

Table 1. Summary of core debris shipping campaign

<u>Cask Shipment Number</u>	<u>Rail Shipment Number</u>	<u>TMI Shipping Date</u>	<u>Arrival at INEL</u>	<u>Return to TMI</u>	<u>Accumulated Number of Canisters</u>
001	001	07/20/86	07/24/86	08/12/86	7
002	002	08/31/86	09/04/86	10/09/86	14
003	002	08/31/86	09/04/86	09/26/86	21
004	003	12/14/86	12/17/86	01/23/87	28
005	003	12/14/86	12/17/86	12/30/86	35
006	004	01/11/87	01/14/87	02/04/87	42
007	005	02/01/87	02/04/87	02/26/87	49
008	006	02/15/87	02/18/87	03/07/87	56
009	007	03/22/87	03/26/87	04/20/87	63
010	007	03/22/87	03/26/87	04/16/87	70
011	008	06/21/87	06/25/87	07/10/87	77
012	008	06/21/87	06/25/87	07/15/87	84
013	009	07/26/87	07/30/87	08/19/87	91
014	009	07/26/87	07/30/87	08/26/87	98
015	010	09/13/87	09/17/87	10/03/87	105
016	010	09/13/87	09/17/87	10/10/87	112
017	011	10/25/87	10/29/87	11/15/87	119
018	011	10/25/87	10/29/87	11/24/87	126
019	012	11/15/87	11/19/87	12/08/87	133
020	013	12/20/87	12/24/87	01/09/88	140
021	013	12/20/87	12/24/87	01/18/88	147
022	013	12/20/87	12/24/87	01/27/88	154
023	014	02/07/88	02/11/88	02/27/88	161
024	014	02/07/88	02/11/88	02/24/88	168
025	014	02/07/88	02/11/88	03/07/88	175
026	015	04/10/88	04/14/88	05/09/88	182
027	015	04/10/88	04/14/88	04/27/88	189
028	015	04/10/88	04/14/88	05/03/88	196
029	016	05/22/88	05/25/88	06/25/88	203
030	016	05/22/88	05/25/88	07/03/88	210
031	016	05/22/88	05/25/88	07/11/88	217
032	017	12/18/88	12/22/88	01/25/89	224
033	017	12/18/88	12/22/88	01/27/89	231
034	017	12/18/88	12/22/88	02/06/89	238
035	018	02/19/89	02/23/89	03/18/89	245
036	018	02/19/89	02/23/89	03/28/89	252
037	018	02/19/89	02/23/89	03/12/89	259
038	019	06/18/89	06/22/89	07/08/89	266
039	019	06/18/89	06/22/89	07/15/89	273
040	019	06/18/89	06/22/89	07/23/89	280
041	020	08/13/89	08/16/89	08/31/89	287
042	020	08/13/89	08/16/89	09/07/89	294
043	020	08/13/89	08/16/89	09/18/89	301
044	021	12/17/89	12/21/89	02/24/90	308
045	021	12/17/89	12/21/89	02/10/90	315
046	021	12/17/89	12/21/89	03/05/90	322
047	022	04/15/90	04/18/90	05/06/90	328
048	022	04/15/90	04/18/90	Storage ^a	335
049	022	04/15/90	04/18/90	Storage ^a	342

a. Casks were placed in storage on railcars located at the Central Facilities Area of the INEL.

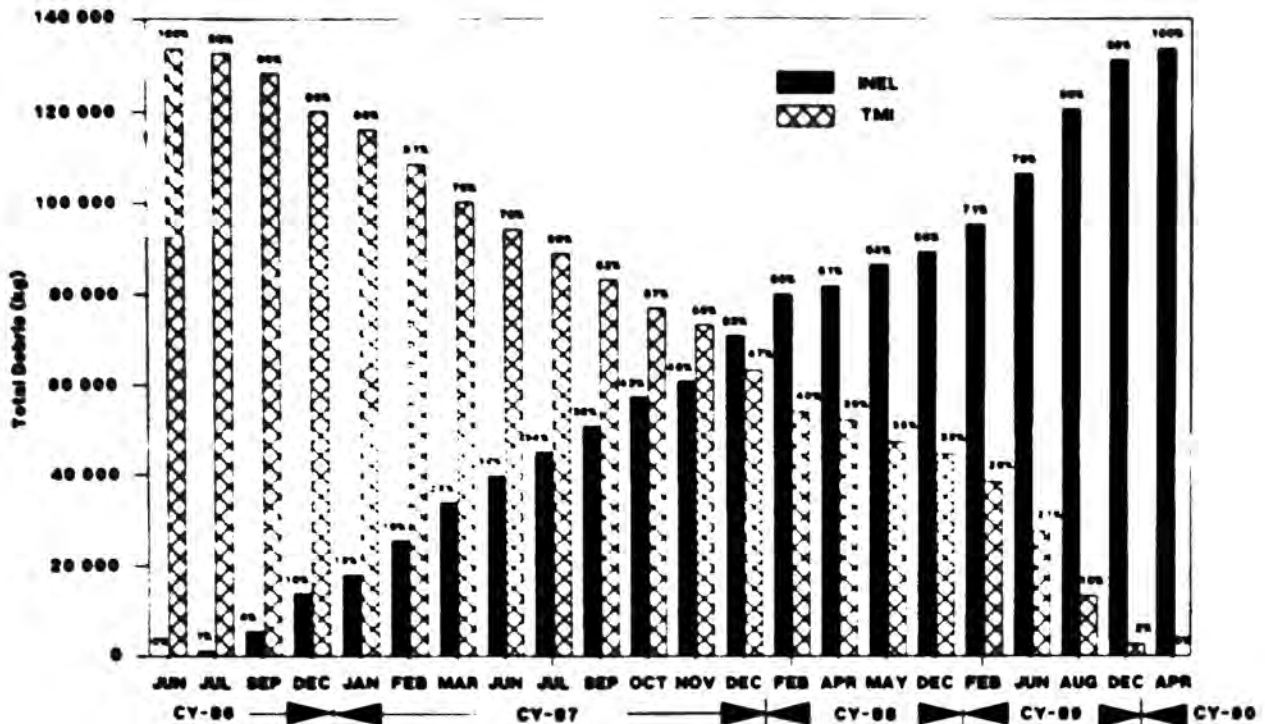

Figure 1. Location of TMI-2 core debris—Three Mile Island versus Idaho National Engineering Laboratory.

which the material in each of the TMI-2 canisters is accounted for and tracked at the INEL. The accountability report will be finalized after GPU Nuclear (a) completes its accounting of the fuel material remaining at TMI-2, and (b) provides DOE with a total accounting of the material transported to the INEL for storage.

2.4 Abnormal Wastes

In 1985 DOE and GPU Nuclear signed contract DE-SC07-85ID124554, entitled "Transportation, Storage, Disposal Services for Abnormal Wastes from the TMI-2 Reactor." A total of three shipments of abnormal wastes have occurred under the contract: two in 1987 and one in 1988. No shipments were made during 1989 and 1990. The wastes were transported to the INEL and are stored in a concrete cask until disposal facilities exist for this class of wastes or until the wastes are otherwise processed for disposal. The cask is located on a concrete pad outside the TAN Hot Shop. The abnormal wastes are contained in three CUNO filters. CUNO filters were used in the submerged demineralizer system, the water treatment system used at TMI-2 to remove contaminated particles

from contaminated water generated by the TMI-2 accident.

The contract period expired in December 1989 between DOE and GPU Nuclear for acceptance of abnormal wastes. Therefore, DOE is not expected to accept any additional abnormal wastes. Also, the TAN Hot Shop at the INEL continues to have the responsibility for monitoring the wastes. Disposition of the three CUNO filters had not been initiated by the end of 1990.

2.5 TMI-2 Records Management

A TMI-2 records file system of the DOE programmatic effort in support of the TMI-2 cleanup is in process of being completed at the INEL. The records file system is a computerized database index of documents relating to DOE efforts in the research, development, and cleanup of TMI-2. These documents are being placed on microfiche copies and will be stored at the INEL Technical Library located in Idaho Falls, Idaho. The computerized database and microfiche copies will be accessible to anyone wanting information about TMI-2 research, development, and cleanup activities.

3. ACCIDENT EVALUATION PROGRAM

3.1 DOE Accident Evaluation Program

The March 1979 accident at the TMI-2 nuclear reactor was the most severe accident to occur at a commercial-operating power reactor in the United States. Examinations of the reactor core, performed as part of the TMI-2 Accident Evaluation Program, indicated that about half the core melted and about 20 metric tons of molten core material relocated from the central core region to the lower head region of the reactor vessel.

DOE sponsored the TMI-2 Accident Evaluation Program to take full advantage of an important wealth of information provided by the TMI-2 accident. The objectives of the DOE Accident Evaluation Program are to:

- Understand what happened during the accident in terms of core melt progression; fission-product retention and transport; and material temperatures, oxidation, and interactions
- Develop an accident scenario based upon this understanding
- Produce a computerized database containing TMI-2 research results, examination data, and supporting analyses; using the database to produce a standard problem exercise to determine possible nuclear accident scenarios.

Sample acquisition and examination of materials from the reactor vessel, the reactor coolant system, and the reactor containment and auxiliary buildings were conducted during the course of the DOE Accident Evaluation Program. *U.S. Department of Energy Three Mile Island Research and Development Program 1988 Annual Report*, GEND Report No. 064, dated April 1989 provides details and results of these examinations.

The following sections of this report describe the progress of the Accident Evaluation Program during 1990. The sections are:

- Final TMI-2 accident scenario

- TMI-2 database and standard problem exercise
- Sample acquisition and examination program.

3.1.1 Final TMI-2 Accident Scenario. The final TMI-2 accident scenario has been refined and formulated based upon examinations performed through 1989. A description of the accident is provided in DOE/ID-10289, *U.S. Department of Energy Three Mile Island Research and Development Program 1989 Annual Report*, dated July 1990.

During 1990, a final detailed report of the TMI-2 accident scenario was completed and is scheduled for publication during 1991.

3.1.2 TMI-2 Database and Standard Problem Exercise. Standard problem exercise calculations, based upon the TMI-2 database, were completed during 1990 by an international task force of the Organization for Economic Cooperation and Development (OECD). A summary report was prepared and review comments were obtained from OECD. This report is scheduled for publication during 1991. It summarizes differences in the various code-calculated results for the TMI-2 accident and identifies the limitations of the codes used to perform the calculations.

3.1.3 Sample Acquisition and Examination Program. During January, GEND-INF-092, *TMI-2 Core Bore Examinations*, Vols. 1 and 2, was published.^a It documents the results of chemical and metallurgical analyses of samples obtained from the lower part of the TMI-2 reactor core. This report is one of the principal products of the TMI-2 Core Examination Program.

No additional core examinations were performed as part of the TMI-2 Accident Evaluation Program during 1990. However, a summary review of existing examinations, performed by participants in the OECD core examination program, was completed in Japan during June 1990. The results of examinations performed by the various countries were summarized in a report that was presented to

a. See Appendix A for a complete list of TMI documents published during 1990.

the OECD Committee on the Safety of Nuclear Installation (CSNI) and the authors for final review during September 1990. The draft report, EGG-OECD-9168, *TMI-2 Examination Results from the OECD-CSNI Program*, Vols. 1 and 2, will be published during 1991. It will summarize the results of the international investigators participating in this OECD core examination program.

3.2 NRC Reactor Vessel Investigation Project

During this 1990 in-vessel metallurgical sampling program, sponsored by NRC, 31 samples were obtained from the bottom head region of the reactor vessel for research purposes. This project is expected (a) to generate research important to the enhancement of nuclear safety and (b) to increase the understanding of the dynamics and consequences of how a reactor vessel responds to molten fuel.

Upon completion of the sample recovery operations, the following 31 samples were obtained, placed inside special sample containers, and removed from the bottom head region of reactor vessel:

- 11 "boat" samples without incore instrument nozzles
- 4 "boat" samples with incore instrument nozzles
- 14 incore instrument nozzle samples
- 2 incore instrument guide tube samples.

Figure 2 (see Section 4) illustrates the location

of the bottom head region of the reactor vessel along with the locations of incore instrument nozzles and incore instrument guide tubes.

The "boat" samples consisted of wedge-shaped pieces cut from the 13-cm thick, reactor vessel bottom head. Each sample was 15-cm long and 7.5-cm deep. The principal tooling used for cutting the "boat" samples was a special underwater metal disintegration machine. Four "boat" samples were cut from vessel bottom surface areas with incore instrument nozzle remnants or stubs intact; 11 "boat" samples were cut from surface areas without incore instrument nozzle stubs. The 14 incore instrument nozzle samples were cut off using an abrasive saw. The incore instrument guide tube samples were cut using a hydraulically driven pipe cutter.

During the cutting of the 11 "boat" samples without incore instrument nozzles, one sample removed in the cutting sequence was taken from an apparent cracked area of the bottom head of the reactor vessel. This cracked area was initially observed during defueling activities conducted in July 1989 (see DOE/ID-10289, *U.S. Department of Energy Three Mile Island Research and Development Program 1989 Annual Report*, dated July 1990). From a video inspection of the sample, it appeared that surface cracking extended deeper into the base metal of the bottom head than was initially believed. However, still photographs, taken after the sample was removed from the reactor vessel, showed no evidence of significant crack propagation. Further analysis of the sample was performed under laboratory conditions. The analysis revealed that no cracks existed beyond the 0.48-cm thick, stainless steel-cladding of the 13-cm thick, carbon-steel bottom head.

4. TECHNICAL INTEGRATION PROGRAM

4.1 Reactor Evaluation Program

During January 1990, final cleanup and video inspection of the TMI-2 reactor vessel was completed. This effort resulted in the cumulative removal to date of 99+% of the original postaccident debris material.

Defueling activities during 1990 included the following:

- Final defueling and cleanup of the reactor vessel
- Video inspection of the reactor vessel.

On March 30, 1990, the DOE Technical Integration Office at Three Mile Island was closed on schedule. The office opened in November of 1979, shortly after the TMI-2 accident, to coordinate defueling and cleanup activities at Three Mile Island.

4.1.1 Fuel and Core Debris Removal

4.1.1.1 Final Reactor Vessel Defueling and Cleanup. Final cleanup was accomplished after the disassembly and defueling of the lower core support assembly (LCSA), defueling of the bottom head region of the reactor vessel, and disassembly and defueling of the upper core support assembly (UCSA) baffle plates. This activity was accomplished during 1988 and 1989. Figure 2 illustrates the location of the LCSA, bottom head region, and UCSA.

Detailed descriptions of these defueling activities are discussed in the following reports: (a) GEND Report No. 064, *U.S. Department of Energy Three Mile Island Research and Development Program 1988 Annual Report*, dated April 1989, and (b) DOE/ID-10289, *U.S. Department of Energy Three Mile Island Research and Development Program 1990 Annual Report*, dated July 1990. These reports also provide information about equipment, such as the pick-and-place vice-grip tool and pump-lift vacuuming system, and other methods used in defueling the TMI-2 reactor vessel.

Final defueling and cleanup inside the reactor vessel was concluded in January 1990. The defueling

and cleanup operations started at the top of the vessel and progressed downward to the bottom of the reactor vessel. These operations involved (a) vacuuming loose debris and fuel fines and (b) pick-and-place removal of fuel rod stubs and debris or "rocks" too large to be vacuumed from the bottom head of the reactor vessel. Pick-and-place operations were conducted with a hydraulically operated vice-grip tool. Debris from these operations was collected in debris buckets and then loaded into fuel canisters for transfer out of the vessel. Vacuuming was accomplished using a pump-lift vacuuming system designed to remove fine debris.

During the final cleanup, shrouds that had been placed over the baffle plates on the UCSA region of the vessel, were cleaned and removed from the reactor vessel. These shrouds were temporarily installed in the vessel following disassembly of the baffle plates and defueling of the core former region of the UCSA (see Figure 2). The purpose of the shrouds was to prevent agitated debris fines from redepositing in the defueled core former region during defueling operations performed after UCSA defueling.

4.1.1.2 Reactor Vessel Video Inspection.

Upon completion of final defueling and cleanup activities, a postdefueling, comprehensive video inspection was conducted to survey for any residual fuel located in the reactor vessel. The inspection was performed using a color camera mounted on a long-handled tool. The inspection started at the top level of the reactor vessel and progressed downward to bottom head region of the vessel.

The video inspection revealed regions in the reactor vessel where additional cleanup was required. While most of the reactor vessel surfaces were clean to the metal, other areas contained a light dusting of core debris fines. As a result of this inspection, the "B" hot leg located in the core support shield region of the reactor (see Figure 2) was revacuumed. Additional vacuuming was also conducted in the UCSA where heavier concentrations of material were found.

Based upon a technical assessment of the visual evidence provided by video inspection, GPU Nuclear determined that an acceptable degree of reactor

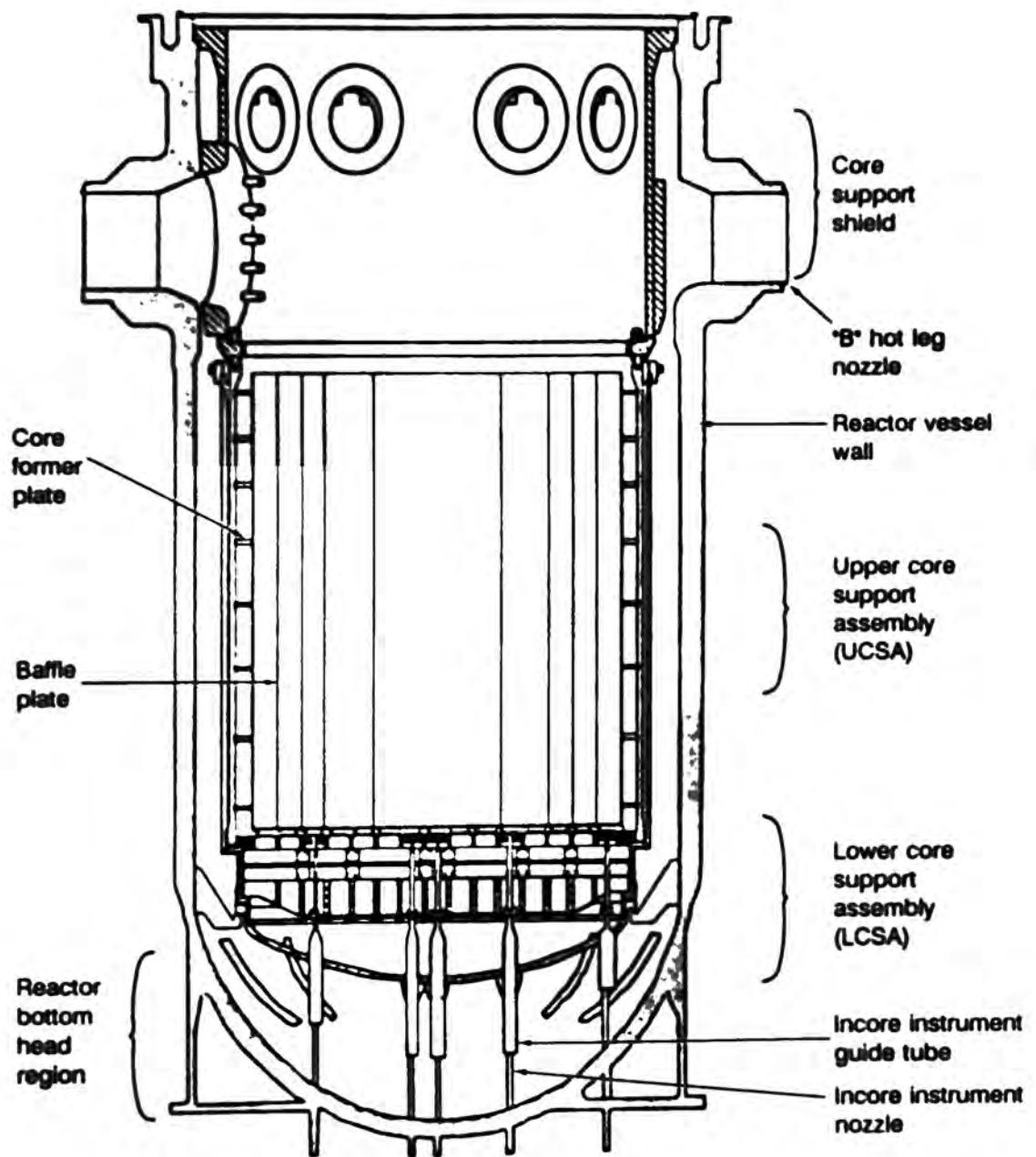

Figure 2. Cutaway view of the TMI-2 reactor vessel.

vessel cleanup had been effectively attained following a four-year period of active defueling operations. The small quantity of core material remaining in the vessel was in compliance with the reactor vessel defueling goal to reduce the fuel remaining in the vessel to less than 1% of the original fuel inventory.

Final decontamination activities to prepare TMI-2 for long-term storage continued throughout 1990. Decontamination work will ultimately involve the Reactor Building, the Auxiliary and Fuel Handling Building, and the evaporation of 2.3 million gal of slightly radioactive, processed water. The TMI-2 plant will be ready for monitored storage in 1991.

4.1.1.3 Reactor Vessel Investigation Project Cleanup. Following final cleanup and inspection of the reactor vessel in January, metallurgical samples were obtained during February from the reactor vessel for the NRC-sponsored Reactor Vessel Investigation Project. The project is described in Section 3.

Sample gathering activities included the use of an abrasive saw and a special underwater metal disintegration machine to cut samples from selected areas inside the vessel. As a result of these cutting activities, additional cleanup was necessary. The initial effort involved pick-and-place removal of debris too large for vacuuming. This effort was followed by vacuuming of loose debris from various in-vessel locations. Cleanup was accomplished during the first weeks of March. During mid-March, confirmatory video inspections were performed inside the vessel to determine the effect of the cleaning operations. Review of the inspections

confirmed that the cleanup was complete.

4.1.2 DOE Technical Integration Office. The DOE Technical Integration Office at Three Mile Island, operated by EG&G Idaho, Inc., for DOE, was closed on March 30, 1990. This marked the end of over 10-1/2 years of DOE and DOE contractor (EG&G Idaho) presence at Three Mile Island.

The Technical Integration Office (TIO) officially opened in November 1979, shortly after the TMI-2 accident. TIO was the focal point for the implementation of DOE's role, mandated by the U.S. Congress, to participate in the TMI-2 cleanup program, learn from the accident, transfer the knowledge gained to the nuclear industry, and sponsor original research into nuclear reactor safety issues. The office coordinated activities involving several DOE national laboratories, other federal agencies, state and local agencies, private enterprise, foreign countries, and GPU Nuclear Corporation (the Three Mile Island utility).

Upon closing TIO, the remaining DOE TMI-2 programmatic functions were transferred to the INEL, a process that has been ongoing for the past two years. The remaining work that will carry into 1991 is relatively minor. It will consist of records management closeout; final waste disposition activities; completion of program reporting and documentation, including the publication of a report on the history and evaluation of the TMI-2 transport and storage campaign; and minor program closeout activities. As part of the closeout activity, this 1990 annual report will be the final annual report of the Three Mile Island program. The scope of these final closeout activities is not sufficient to warrant another annual report.

APPENDIX A
1990 TMI-2 PUBLICATIONS

Index of 1990 TMI-2 Publications

D. W. Akers et al., *TMI-2 Core Bore Examinations*, Vols. 1 and 2, GEND-INF-092, January 1990.

R. C. Schmitt et al., *TMI-2 Lessons Learned by the U.S. Department of Energy—A Programmatic Perspective*, DOE/ID-10276, Idaho National Engineering Laboratory, U.S. Department of Energy, Idaho Operations Office, Idaho Falls, ID, March 1990.

Offsite Shipment of Defueling Canisters, Technical Bulletin 86-33, Rev. 20, GPU Nuclear Corporation, Middletown, PA, May 30, 1990.

U.S. Department of Energy Three Mile Island Research and Development Program 1989 Annual Report, DOE/ID-10289, Idaho National Engineering Laboratory, U.S. Department of Energy, Idaho Operations Office, Idaho Falls, ID, July 1990.

